

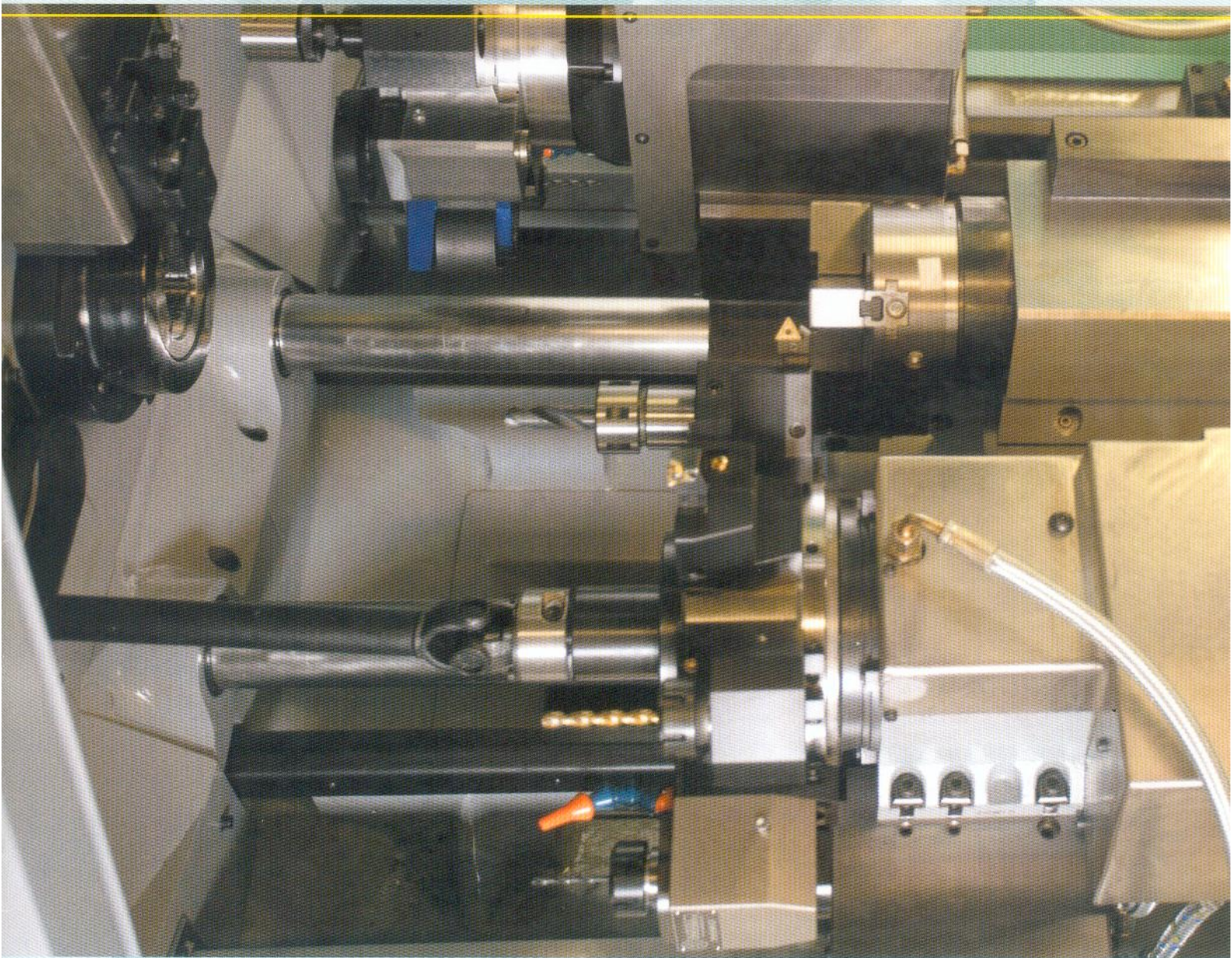

THE NEW CONCEPT

AUTOMATIC CNC LATHE OMEGA

MODELS: OMEGA 30 / 42 / 65 / 80



NEW CONCEPT GIVING ALL MACHINING POSIBILITIES



OMEGA PARTICULARITIES: OMEGA 30 / 42 / 65 / 80

MUPEM CNC AUTOMATIC LATHE MOD. OMEGA 30 / 42 / 65 / 80 WITH 6 CNC CONTROLLED AXIS

The OMEGA model represents the logical evolution to complete our machines range starting from bar. This is the ideal machine for those parts needing strong machinings on both sides, keeping all the flexibility, possibilities and reliability from its FANUC 16i – T control.

Robustly built, this machine allows machinings with hard metal inserts at very high cutting speeds. Its widespread control allows the most precise and reliable machinings to reach the best quality and accuracy on your machined parts.

The ergonomics and its stylish lines are the result of a very careful design integrating the highest technology involved in the OMEGA model.

The full range of bar capacities for this model are the following: 30 / 42 / 65 / 80 mm. There is a wide choice of optional attachments to make a customised configuration of the machine in accordance with the customers' needs.

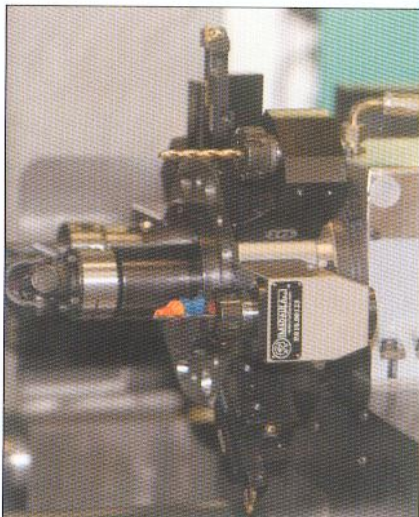
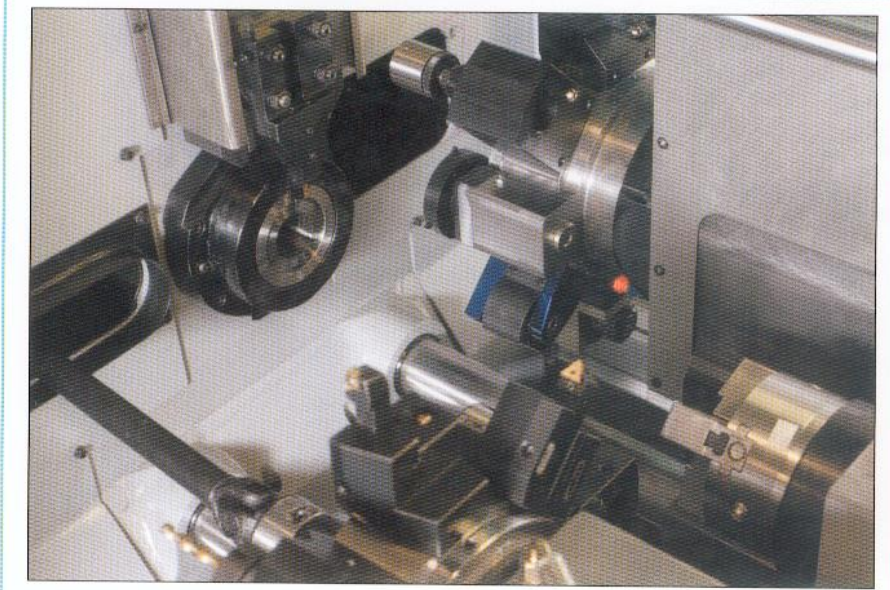
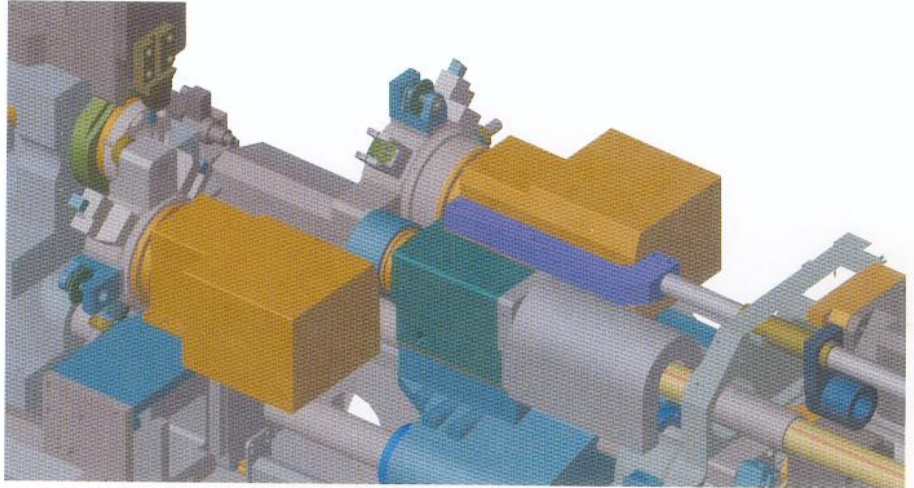

ADVANTAGES OF THE OMEGA MODEL

- Two turrets able to work simultaneously on both the main spindle and the counterspindle.
- Synchronous counterspindle with its own CNC axis. (Optional)
- Vertical slide for cutting off or simultaneous profiling located above the main spindle.
- CNC polygonal turning and threads milling device on the turret.
- No telescopic protections to care for.
- The turrets motors and the counterspindle's motor are outside the working area with no need for servicing.
- This machine is ready to be fitted with four different counterpindles (capacities) or one tailstock.
- This machine may work starting from bars or loading individual parts with the tailstock.

SIMULTANEOUS MACHINING EXAMPLES

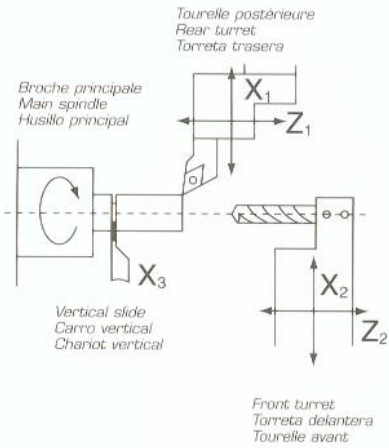

1

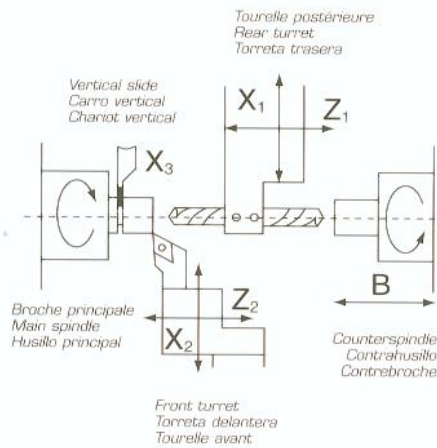

2

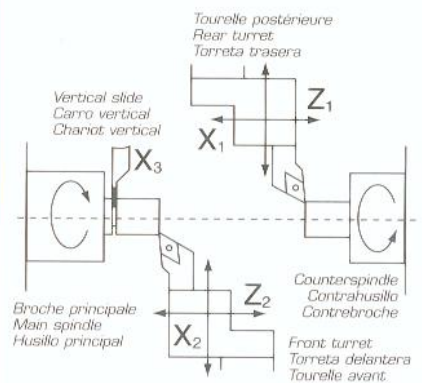

Possibility to work simultaneously on the main spindle and the counterspindle
 Trabaja simultáneamente tanto en el husillo principal como en el contrahusillo
 Usinage simultané sur la broche principale et la contrebroche

3

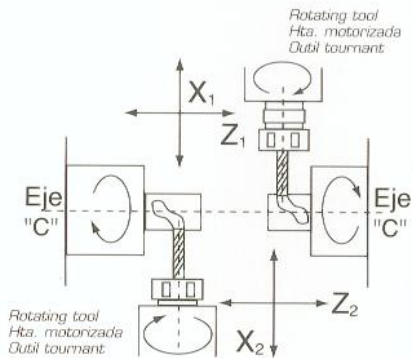

Optionally, both spindles may have "C" axis
 Como opción, ambos husillos pueden tener eje "C"
 En option, les deux broches peuvent être équipées avec un axe "C"

4

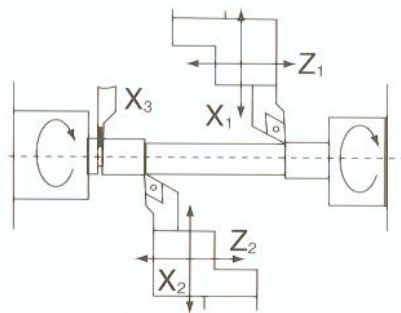

Long parts machining with the help of the subspindle
 Mecanizado de piezas largas con ayuda del contrahusillo
 Usinage de pièces longues à l'aide de la contrebroche

5

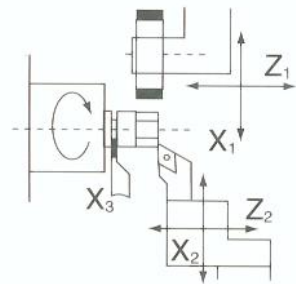

CNC polygonal turning/threads milling device fitted on the rear turret
 Dispositivo de torneado poligonal / fresado roscas CNC en la torreta trasera
 Dispositif de tournage polygonal / fraisage de filets à C.N. sur tourelle arrière

6

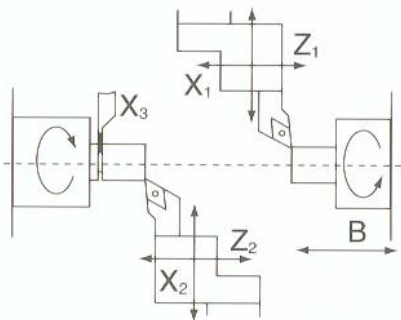

Simultaneous machining on both spindles. Time savings
 Mecanizado simultáneo en ambos husillos. Ahorro de tiempo
 Usinage simultané sur les deux broches. Gains de temps

7

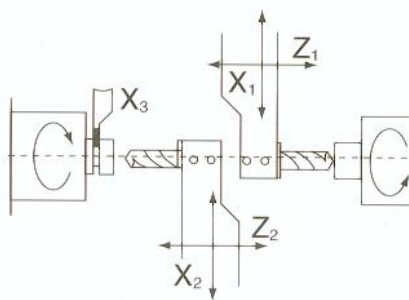

Simultaneous machining on both spindles. Time savings
 Mecanizado simultáneo en los dos husillos. Ahorro de tiempo
 Usinage simultané sur les deux broches. Gains de temps

8

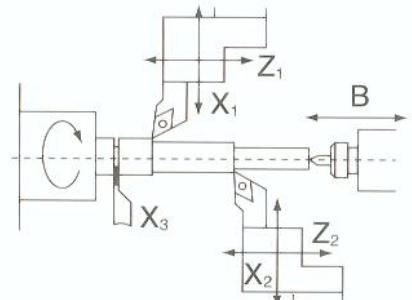

Long parts machining with the help of a tailstock
 Mecanizado de piezas largas con la ayuda de un contrapunto
 Usinage de pièces longues à l'aide d'une contrepointe

9

OMEGA: HI-TECH INSIDE

TECHNICAL FEATURES

BED

Its perlite cast iron bed has been specially designed using the most advanced CAD - CAM - CAE equipment with finite elements calculation features to insure the highest rigidity and at the same time, to avoid guides heating, insuring the optimal swarf evacuation along with the best coolant recollection equipped with an independent tank.

MAIN SPINDLE

The main spindle is tempered and grinded, fitted with high precision bearings. Dynamically balanced to insure a precision concentricity and high quality finishings. Ready to accept standard collet clamping systems (DIN 6343, HAINBUCH BZI and CRAWFORD)

Collet clamping system is operated by an hydraulical cylinder AUTO-BLOCK fitted with detection and security systems.

High torque AC operations for the main spindle with continuous speed variation and 7,5 / 11 kW in the 30 and 42 models and 11 / 15 kW in the 65 / 80 models

As an option, the main spindle may be fitted either with a "C" axis or with a stop and positioning device in order to be able to make cross drillings, millings and excentric drillings from both turrets.



CONTROL

As a standard, the machine is sold with the FANUC 16i - T control bringing ahead its well known reliability and accuracy of its turning, drilling, tapping cycles along with the possibility to have a "C" axis and many more important features, like outside PC programming via RS-232 and Ethernet.



TAILSTOCK

The OMEGA model may be equipped with an hydraulically operated tailstock as an option. The positioning of the tailstock is manual. The tailstock's rod is \varnothing 60 mm with an 80 mm stroke and morse cone 4.





CYLINDRICAL AND LINEAR GUIDES

The OMEGA machine is built with a highly rigid and modern guides system which is a combination between cylindrical and linear ball recirculating guides.

A perfectly smooth sliding is granted thanks to the Glicodur pillow blocks protected with scrapers and the automatic lubricating system.

This combination between one cylindrical guides and two linear guides for each slide has been successfully tested and widely used by MUPEM for many years. It allows a maximum precision and surface quality keeping at all times the tolerances.

TURRETS

Two eight positions VDI-30 turrets fitted on each of both horizontal slides. High speed bidirectional indexing by the shortest way and HIRTH locking system. The movement along the X and Z axis is totally independent and CNC controlled, allowing the linear and circular interpolation between both axis. Both turrets may work simultaneously or independently on the workpiece.

As an option, both turrets may have up to 4 rotating tools in order to achieve :

- Quick drillings
- Differential tappings (without inverting the main spindle)
- Excentric drillings and tappings
- Millings, etc.

Both turrets are ready to fit an internal tool cooling system. The standard cooling system pump gives up to 2 bar pressure and, as an option, we may fit a 4 bar pressure pump.

To enhance this machine's capabilities, we may fit the rear slide turret with a "Y" axis with a ± 30 mm stroke.

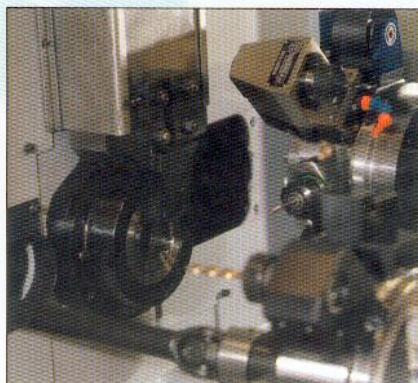

LUBRIFYING EQUIPMENT

Centralized lubricating system for all the machine.

AIR EQUIPMENT

The air filtering group is fitted with a presostat and automatic blow off system to grant the pressurization system efficiency.

HYDRAULICAL GROUP

The hydraulic group has an independent pumping station with accumulator along with a oil temperature conditioner, with pressure and tank lines filtering system.

ELECTRICAL CABINET

Widely dimensionated to avoid components overheating with intercooler and electrical noise filtering elements. As an option, and for extreme temperatures working conditions, the machine may be equipped with an electrical cabinet air conditioning device.

BODY AND CE NORMS COMPLYING

This machine is fitted with all the required systems to comply with security related CE norms. The working area is totally closed preventing from coolant splashes with a sliding door fitted with a non-shattering glass and security system when opening.



OPTIONAL ATTACHMENTS

SYNCHRONISED COUNTERSPINDLE

The OMEGA model may be optionally equipped with a synchronised counterspindle which is very useful when the parts to be machined need hard machining on the back side. Avoiding the need to finish the part on a secondary operation.

There are 4 different counterspindle's versions with regards to its bar passage capacity 42 / 60 and 80 mm with mechanical collet clamping system and an other counterspindle fitted with a $\varnothing 130 / \varnothing 37$ mm bar passage three jaws chuck with an

hydraulic clamping system operated by a hydraulic cylinder. The counterspindle may be fitted with a part expulsion system instead of being only passing through along with an internal coolant system for collet or chuck cleaning. The maximum stroke of this counterspindle along the "Z" axis is of 300 mm.

There is the possibility to fit a stop and positioning system for this counterspindle or a full "C" axis.

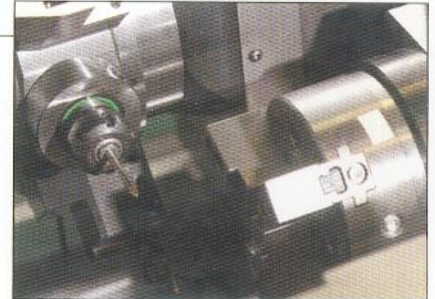

CENTRAL VERTICAL SLIDE

In order to have an other additional tool for cutting off, for instance, there is the option to fit a vertical slide above the main spindle. Hydraulically operated and CNC controlled by the means of one electrovalve and a pressurised optical

scale. The pressurisation of the optical scale cares for the scale protection against coolant splashes and swarf. The vertical slide radial stroke is of 70 mm with an axial manual adjustment up to 50 mm.

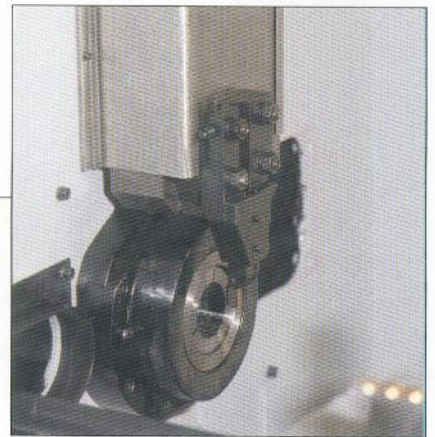

REAR TURRET WITH "Y" AXIS

On request, the rear turret may be enhanced with an "Y" axis having 70 mm stroke (+40 / -30) and being able to work either on the main spindle or on the counterspindle.

Its particularly robust construction allows any kind of milling or other machinings off the workpiece center.

OPTIONAL ATTACHMENTS

- Central vertical slide with 70 mm stroke along the "X" axis CNC controlled and 50 mm axial manual adjustment.
- Synchronised counterspindle with $\varnothing 130$ mm chuck or DIN 6343 $\varnothing 42$ mm collet and hydraulic cylinder with 37 mm bar passage.
- Synchronised counterspindle with DIN 6343 collet, maximum capacity of $\varnothing 42$ mm.
- Synchronised counterspindle with DIN 6343 collet, maximum capacity of $\varnothing 60$ mm.
- Synchronised counterspindle with a special $\varnothing 80$ mm bar passage in 180 mm and with $\varnothing 60$ mm bar passage capacity with DIN 6343 collet.
- Pneumatically operated workpiece expulsion system with air / coolant system for collet cleaning.
- Rear part expulsion system through the counterspindle.
- Stop and positioning of the main spindle every 5°
- Full "C" axis on the main spindle
- Stop and positioning of the counterspindle every 5°
- Full "C" axis on the counterspindle
- CNC Polygonal turning / Thread milling device fitted on the rear turret
- CNC polygonal turning and thread milling device at 180° on the rear turret
- Rear turret with "Y" axis and 70 mm stroke (+40 / -30) capable to work either on the main spindle or the counterspindle.
- Rotating tools for the each of the turret, 5,5 kW and 6.000 rpm.
- Swarf conveyor with coolant tank incorporated
- Paddle swarf conveyor with coolant tank incorporated
- Part catcher and extractor
- Hydraulic tailstock with $\varnothing 60$ mm rod and 80 mm stroke and Morse cone 4
- Eccentric turning device in the main spindle
- Oil mist extractor
- Hydraulic monotube or multitube bar feeders
- Automatic bar feeders



TECHNICAL FEATURES

TECHNICAL FEATURES		OMEGA 30	OMEGA 42	OMEGA 65	OMEGA 80
HEADSTOCK					
ROUND BAR MAX. CAPACITY	MM	30	42	65	80
CHUCK MAX. DIAMETER	MM	-	-	-	-
SPINDLE'S FRONT BEARING DIAMETER	MM	55	100	100	110
MAX. DIAMETER DIN 6343 COLLETS	MM	30	42	65	80
MAX. DIAMETER HAINBUCH - BZI COLLETS	MM	30	42	65	80
MAX. SPINDLE SPEED	RPM	6000	4500	3000	2500
STANDARD POWER	KW(100/50%ED)	7,5/11	7,5/11	11/15	11/15
OPERATION TYPE		ASYNCHRONOUS VECTORIAL			
TURRETS					
TOOLS NUMBER	#	8 EACH ONE			
TOOLS SHANK BORE DIAMETER	Ø	VDI-30			
FRONT TURRET RADIAL STROKE X1	MM	120			
REAR TURRET RADIAL STROKE X2	MM	100			
FRONT TURRET AXIAL STROKE Z1	MM	415			
REAR TURRET AXIAL STROKE Z2	MM	380			
RAPID TRAVERSE	M/MIN	15			
FEED FORCE	N	6790			
CONSECUTIVE POSITION INDEXING AND LOCKING	SEG	0,15			
180° INDEXING AND LOCKING	SEG.	0,50			
INDEXING SYSTEM	-	BIDIRECTIONAL BY THE SHORTEST WAY			
LIVE TOOLS ON THE TURRET (OPTIONAL)					
NUMBER OF LIVE TOOLS	#	4 EACH ONE			
LIVE TOOLS POWER	KW (50% ED)	5,5			
LIVE TOOLS MAX. SPEED	RPM	6000			
POLYGONAL TURNING OR THREADS MILLING	-	CNC CONTROLLED FROM THE TURRET			
POLYGONAL TURNING AND THREADS MILLING	-	AT 180° CNC CONTROLLED FROM THE TURRET			
VERTICAL SLIDE (OPTION)					
NUMBER OF SLIDES	#	ONE VERTICALLY PLACED OVER THE MAIN SPINDLE			
RADIAL STROKE	MM	70			
AXIAL MICROMETRIC MANUAL ADJUSTMENT	MM	50			
RAPID TRAVERSE	M/MIN	10			
FEED FORCE	N	8000			
SYNCHRONISED COUNTERSPINDLE (OPTIONAL)					
A/ SYNCHRONISED COUNTERSPINDLE Ø 42	MECHANICAL	MAX. BAR PASSAGE Δ 42 MM			
AXIAL STROKE Z3	415 MM	MACHINING FROM THE REAR TURRET WITH			
SPINDLE SPEED	SYNCHRONISED WITH THE MAIN SPINDLE	STATIC AND LIVE TOOLS			
POWER	5,5 KW				
STOP AND POSITIONING POSSIBILITY	YES				
"C" AXIS POSSIBILITY	YES				
B/ SYNCHRONISED COUNTERSPINDLE Ø 60	MECHANICAL	MAX. BAR PASSAGE Ø 60 MM			
AXIAL STROKE Z3	415 MM	MACHINING FROM THE REAR			
SPINDLE SPEED	SYNCHRONISED WITH THE MAIN SPINDLE	TURRET WITH STATIC AND LIVE TOOLS			
POWER	5,5 KW				
STOP AND POSITIONING POSSIBILITY	YES				
"C" AXIS POSSIBILITY	YES				
C/ SYNCHRONISED COUNTERSPINDLE Ø 80	MECHANICAL	MAX. COLLET Ø 80 MM, AND Δ 60 MM BAR			
AXIAL STROKE Z3	415 MM	PASSAGE THROUGH 180 MM			
SPINDLE SPEED	SYNCHRONISED WITH THE MAIN SPINDLE	MACHINING FROM THE REAR TURRET WITH STATIC			
POWER	5,5 KW	AND LIVE TOOLS			
STOP AND POSITIONING POSSIBILITY	YES				
"C" AXIS POSSIBILITY	YES				
D/ CHUCK SYNCHRONISED COUNTERSPINDLE Ø 130 MM	MECHANICAL	MAX. CHUCK Ø 130 MM, MAX. BAR PASSAGE Ø 37 MM			
AXIAL STROKE Z3	415 MM	OR			
SPINDLE SPEED	SYNCHRONISED WITH THE MAIN SPINDLE	DIN 6343 Ø 42 COLLET AND MAX. BAR PASSAGE			
POWER	5,5 KW	OF Ø 37 MM			
STOP AND POSITIONING POSSIBILITY	YES	MACHINING FROM THE REAR TURRET WITH			
"C" AXIS POSSIBILITY	YES	STATIC AND LIVE TOOLS			
TAILSTOCK (OPTIONAL)					
OPERATION	-	HYDRAULIC			
POSITIONING	-	MANUAL			
MORSE CONUS TYPE	-	4			
STROKE	MM	80			
HYDRAULIC SYSTEM					
MAX. WORKING PRESSURE	BAR	70			
TANK CAPACITY	LITRES	110			
COOLING SYSTEM					
FLOW	LITRES / MIN	20			
STANDARD PRESSURE	BAR	4			
TANK CAPACITY	LITRES	200			
DIMENSIONS					
SPINDLE CENTRE HEIGHT ABOVE THE GROUND	MM	1080			
AREA	MM	3300 X 1750			
MAX. MACHINE HEIGHT	MM	1900			
APPROX. WEIGHT	KG	4900			



MANUFACTURING RANGE



OMEGA

CURRENT MACHINES RANGE

- CNC MULTISLIDES AUTOMATIC LATHES
- AUTOMATIC BAR FEEDERS
- HANDLING SYSTEMS
- AUTOMATIC LATHES
- MULTISPINDLE LATHES
- CNC LATHES



TWIN



MIKRA

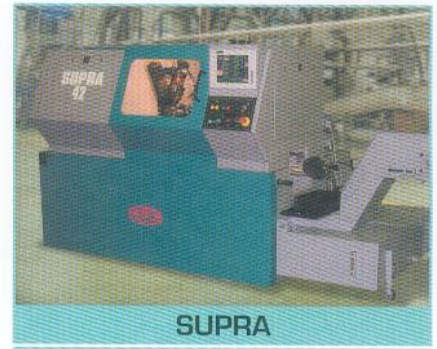

SUPRA



DEBA

These technical specifications may vary without notice due to our continuous improvement policy.



MAGNA



CONSTRUCCIONES MECÁNICAS MUPEM, S.A. Pol. Ind. de Itziar, G1 - E-20829
ITZIAR - DEBA (Gipuzkoa) P.O.BOX 71 - E-20820 DEBA (Spain)
Tif.: (34) 943 199 192 / 943 199 222 / 943 199 252 / 943 199 282 / 943 199 312
Fax: (34) 943 199 221 - e-mail: mupem@mupem.com - web: www.mupem.com